

Screw filter type S-SD

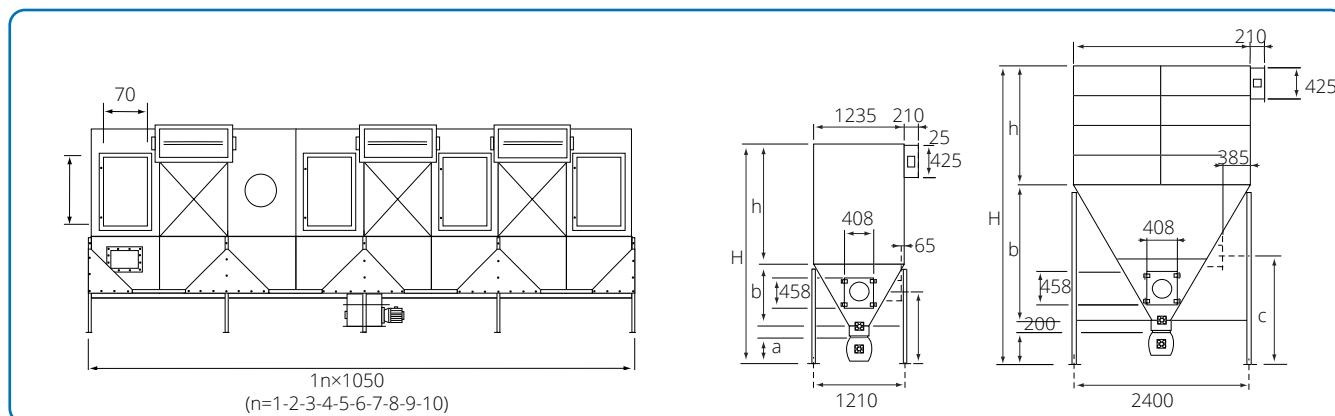

The drawing above shows single and double filters. Measurement specifications are stated in the table at the bottom of the page.

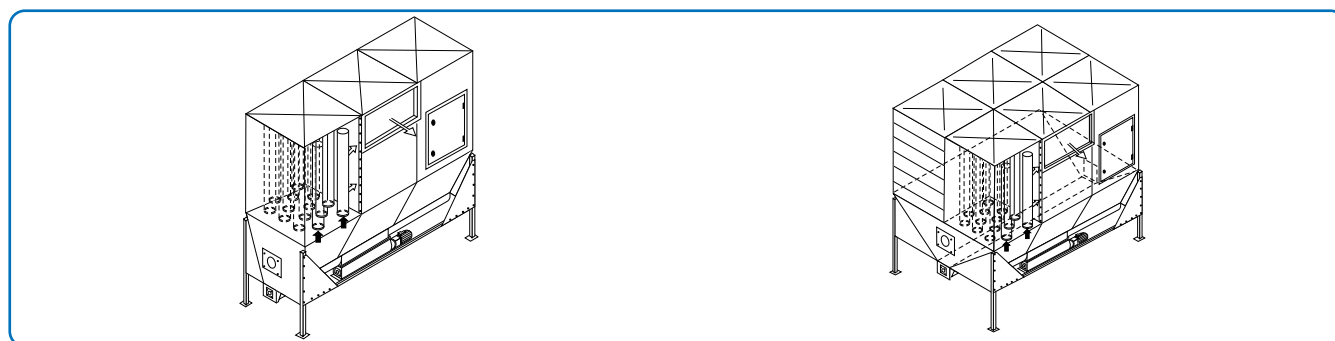

Screw filter type S and double screw filter type SD.

The S - SD screw filter can be used for heavy-duty applications involving large volumes of materials and air.

Supply air enters at the side of the bottom or in a separate air supply module, although never over the material discharge.

If several fans are used for the same filter, a JKF nonreturn flap must be used on the inlets.

The filter is emptied using a screw with discharge from either end towards the middle of the filter, or from one end towards the discharge at the opposite end. The discharge can be located where required.

Connection

Screw

Gear motor

0.55 kW, 22 min⁻¹, 3 x 400 V, 50 Hz, 2.5 A

Dimensions

| Type | a mm | b mm | c mm | h mm | H mm | Bag length mm | Filter area m ² per module | Weight per module kg |
|--------|---------|---------|---------|---------|---------|------------------|--|-------------------------|
| M - S | 400 | 840 | 1080 | 1650 | 3090 | 1580 | 15.5 | 155 |
| M - S | 650 | 840 | 1330 | 1650 | 3340 | 1580 | 15.5 | 160 |
| H - S | 400 | 840 | 1080 | 2100 | 3540 | 2030 | 20.0 | 170 |
| H - S | 650 | 840 | 1330 | 2100 | 3790 | 2030 | 20.0 | 175 |
| E - S | 400 | 840 | 1080 | 2550 | 3990 | 2480 | 24.5 | 185 |
| E - S | 650 | 840 | 1330 | 2550 | 4240 | 2480 | 24.5 | 190 |
| MS - D | 400 | 1860 | 1545 | 1650 | 4110 | 1580 | 31.0 | 310 |
| MS - D | 650 | 1860 | 1795 | 1650 | 4360 | 1580 | 31.0 | 315 |
| HS - D | 400 | 1860 | 1545 | 2100 | 4560 | 2030 | 40.0 | 330 |
| HS - D | 650 | 1860 | 1795 | 2100 | 4810 | 2030 | 40.0 | 335 |
| ES - D | 400 | 1860 | 1545 | 2550 | 5010 | 2480 | 49.0 | 350 |
| ES - D | 650 | 1860 | 1795 | 2550 | 5260 | 2480 | 49.0 | 355 |
| EX - D | 650 | 1860 | 1795 | 3000 | 5710 | 2890 | 58.0 | 375 |